

Motor Switches

BLK Series Explosion-proof Motor Switches (Ex db IIB)



- ◆ Explosion protection to
 - CENELEC
 - IEC
 - NEC
- ◆ Can be used in
 - Zone 1 and Zone 2
 - Zone 21 and Zone 22
 - Class I, Zone 1 and Zone 2
 - Class I, Division 1, Groups C, D
- ◆ Classified as IIB according to gas atmosphere.
- ◆ Copper-free Aluminium Alloy enclosure, powder-coated surface.
- ◆ Built-in MCB (miniature circuit breaker), MCCB (moulded case circuit breaker).
- ◆ Earth leakage protection device is optional.

■ Catalogue number logic

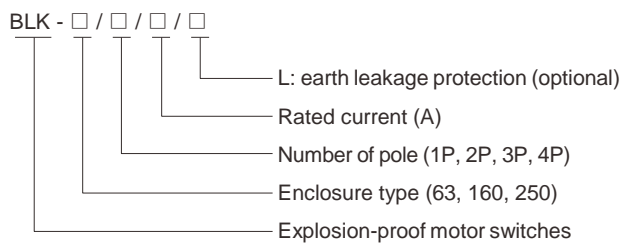

■ Note

1. Please select the model by Catalogue number logic above, and specify all technical data;
2. Please specify Ex-mark when ordering;
3. Entry size and direction on request.

Zones 1&2; 21&22

Motor Switches

BLK Series Explosion-proof Motor Switches (Ex db IIB)

Technical data

Explosion-proof motor switches BLK-63/□/□/□

Explosion protection

Global (IECEX)	IECEX CNEx 18.0034X
Gas and dust	Ex db IIB T6 Gb Ex tb IIIC T80°C Db
Europe (ATEX)	CNEX 18 ATEX 0027 X
Gas and dust	⊕ Ex II 2 G Ex db IIB T6 Gb ⊕ Ex II 2 D Ex tb IIIC T80°C Db

Certificates

IECEX; ATEX

Conformity to standards

EN 60079-0, EN 60079-1, EN 60079-31
IEC 60079-0, IEC 60079-1, IEC 60079-31

Enclosure material

Copper-free Aluminium Alloy, powder coated surface

Enclosure colour

Window grey (RAL7040)

Exposed fastener

Stainless steel

Circuit breaker

MCB (miniature circuit breaker)

Max. working voltage

440V AC 50/60Hz

Rated voltage

1P/230V AC, 2P/3P/4P/400V AC 50/60Hz

Rated current

16A/32A/63A

Number of pole

1P, 2P, 3P, 4P

Breaking capacity

6kA, 10kA, 15kA

Tripping characteristic

Instantaneous tripping range (5~10) In, (7~10) In or (10~14) In

Impulse withstand voltage

6kV

Degree of protection

IP66

Internal&external earthing

M6/M6

Ambient temperature

-60°C~+60°C

Cable entries

Standard 1~16A: 2 x M25 x 1.5 plugs
20~32A: 2 x M32 x 1.5 plugs
40~63A: 2 x M40 x 1.5 plugs

Cable gland (optional)

DQM-II (Ex d) or DQM-III (Ex d) is recommended. Please see P7/22~31

Entry direction

Bottom

Enclosure weight

8.00 kg

Earth leakage protection

On request



Dimension drawings (all dimensions in mm) - subject to alteration

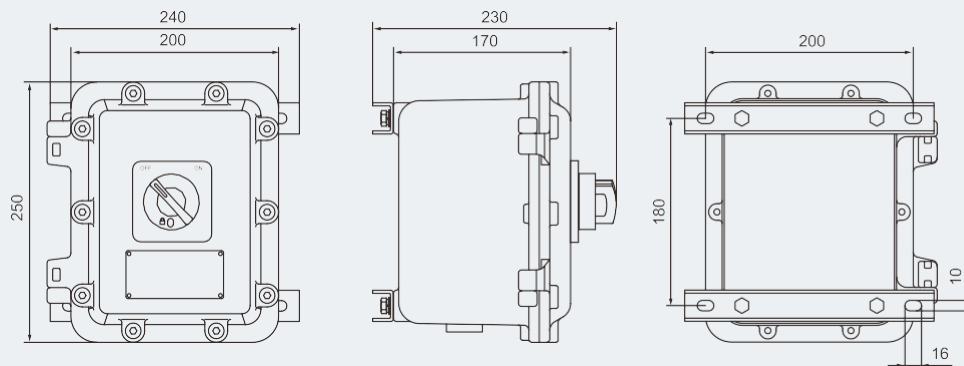

BLK-63/□/□/□

Motor Switches

BLK Series Explosion-proof Motor Switches (Ex db IIB)

Technical data

Explosion-proof motor switches BLK-160/□/□/□

Explosion protection	
Global (IECEX)	IECEX CNEx 18.0034X
Gas and dust	Ex db IIB T6 Gb Ex tb IIIC T80°C Db
Europe (ATEX)	CNEX 18 ATEX 0027 X
Gas and dust	Ⓔ II 2 G Ex db IIB T6 Gb Ⓔ II 2 D Ex tb IIIC T80°C Db
Certificates	IECEX; ATEX
Conformity to standards	EN 60079-0, EN 60079-1, EN 60079-31 IEC 60079-0, IEC 60079-1, IEC 60079-31
Enclosure material	Copper-free Aluminium Alloy, powder coated surface
Enclosure colour	Window grey (RAL7040)
Exposed fastener	Stainless steel
Circuit breaker	MCCB (moulded case circuit breaker)
Max. working voltage	690V AC 50/60Hz 500V DC
Rated current	80A/100A/125A/160A
Number of pole	3P, 4P
Breaking capacity	380/415V AC 50/60Hz, 36kA/50kA 440V AC 50/60Hz, 30kA/45kA
Impulse withstand voltage	8kV
Tripping characteristic	Thermomagnetic type
Degree of protection	IP66
Internal&external earthing	M6/M8
Ambient temperature	-60°C~+60°C
Cable entries	Standard 80~100A: 2 x M50 x 1.5 plugs 125~160A: 2 x M63 x 1.5 plugs
Cable gland (optional)	DQM-II (Ex d) or DQM-III (Ex d) is recommended. Please see P7/22~31
Entry direction	Bottom
Enclosure weight	18.90kg
Earth leakage protection	On request



Dimension drawings (all dimensions in mm) - subject to alteration

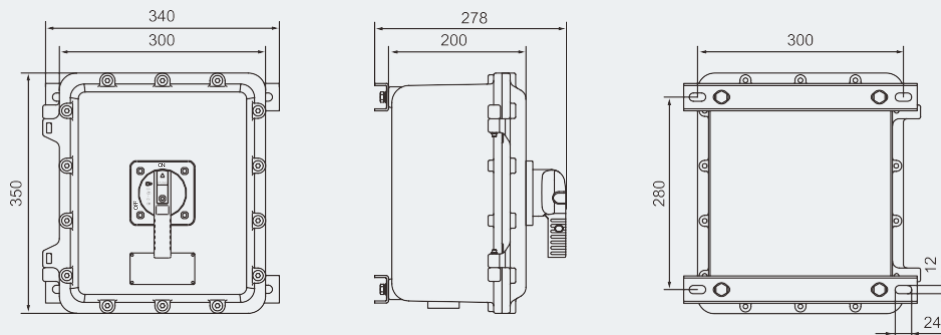

BLK-160/□/□/□

Motor Switches

BLK Series Explosion-proof Motor Switches (Ex db IIB)

Technical data

Explosion-proof motor switches **BLK-250/□/□/□**

Explosion protection

Global (IECEX)	IECEX CNEx 18.0034X
Gas and dust	Ex db IIB T6 Gb Ex tb IIIC T80°C Db
Europe (ATEX)	CNEX 18 ATEX 0027 X
Gas and dust	Ⓔ II 2 G Ex db IIB T6 Gb Ⓔ II 2 D Ex tb IIIC T80°C Db

Certificates

IECEX; ATEX

Conformity to standards

EN 60079-0, EN 60079-1, EN 60079-31
IEC 60079-0, IEC 60079-1, IEC 60079-31

Enclosure material

Copper-free Aluminium Alloy, powder coated surface

Enclosure colour

Window grey (RAL7040)

Exposed fastener

Stainless steel

Circuit breaker

MCCB (moulded case circuit breaker)

Max. working voltage

690V AC 50/60Hz
500V DC

Rated current

200A/250A

Number of pole

3P, 4P

Breaking capacity

380/415V AC 50/60Hz, 36kA/50kA
440V AC 50/60Hz, 25kA/40kA

Impulse withstand voltage

8kV

Tripping characteristic

Thermomagnetic type

Degree of protection

IP66

Internal&external earthing

M6/M8

Ambient temperature

-60°C~+60°C

Cable entries

Standard 2 x M63 x 1.5 plugs

Cable gland (optional)

DQM-II (Ex d) or DQM-III (Ex d) is recommended. Please see P7/22~31

Entry direction

Bottom

Enclosure weight

28.50kg

Earth leakage protection

On request

Note

Rated current > 250A on request.

Dimension drawings (all dimensions in mm) - subject to alteration

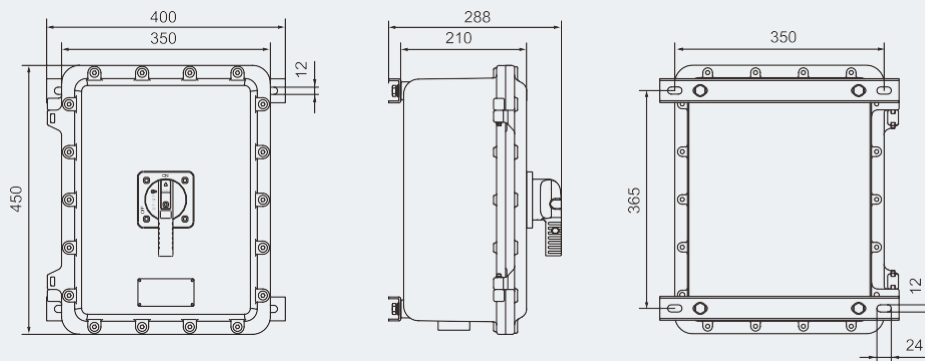

BLK-250/□/□/□

